

## Introduction

Secured by Design is a police initiative to guide and encourage those engaged within the specification, design and build of new homes, and those undertaking property refurbishment, to adopt crime prevention measures. The advice given has been proven to reduce the opportunity for crime and the fear of crime, creating safer, more secure and sustainable environments. Secured by Design is owned by the UK Police Service and is supported by the Home Office. Building Control Departments in England (Part Q Security – Dwellings), Scotland (Building Standard 4.13) and Wales (Part Q Security – Dwellings) all reference SBD

Secured by Design has three differing levels of security award, starting at the highest level (SBD Gold) which incorporates the security of the external environment together with the physical security specification of the home. SBD Silver offers those involved in new developments, major refurbishment and the individual the opportunity to gain an award for the level of physical security provided. In addition, SBD Bronze offers a route to achieve a reasonable level of physical security for bespoke or refurbished properties where a traditional enhanced security product is not available, or cannot be utilised due to the listed building or other conservation status.

## What does it mean for windows and doors ?

### All levels

Window frames must be securely fixed to the building fabric in accordance with the manufacturer's instructions and specifications. These should be made available to the Designing Out Crime Officer (DOCO) upon request if the need for a visual confirmation is felt necessary.

All easily accessible windows shall be certificated to one of the following standards:

- PAS 24:2016;
- A window or doorset, any part of which is within 2 metres vertically of an accessible level surface such as a ground or basement level, or an access balcony.
- A window within 2 metres vertically of a flat roof or sloping roof (with a pitch of less than 30°) that is within 3.5 metres of ground level.

There is a requirement for all emergency egress windows without locking hardware to be installed with sealed units having laminated glass to at least one pane.

All easily accessible windows should incorporate key lockable hardware unless designated as emergency egress routes within the Building Regulations. 22.4 Windows that form part of a designated fire escape route, as determined by the Fire Safety Officer, may require non-key locking hardware.

Windows that are not easily accessible will require either lockable hardware or an opening restrictor in the interests of child safety.

Windows must also be fit for purpose and shall be certificated to the relevant material standard i.e.:

- BS 7412:2007 (PVC-U)
- BS 4873: 2016 (Aluminium)
- BS 6510: 2010 (Steel)
- BS 644: 2012 (Timber).

Laminated glass meeting the requirements of BS EN 356:2000 class P1A is required in the following areas:

- Any window located within 300mm of a doorset (to ensure the integrity of the locking system)
- Easily accessible emergency egress windows with non-lockable hardware (a requirement of PAS 24:2016).
- A window or doorset, any part of which is within 2 metres vertically of an accessible level surface such as a ground or basement level, or an access balcony
- A window within 2 metres vertically of a flat roof or sloping roof (with a pitch of less than 30°) that is within 3.5 metres of ground level.

All doorsets allowing direct access into to the home, e.g. front and rear doors, interconnecting garage doorsets, French doors, bi-fold or sliding patio doorsets, dedicated private flat or apartment entrance doorsets, easily accessible balcony doorsets (Note 21.3a), etc., shall be certificated to PAS 24:2016.

SBD Level	Windows	Doors
Gold	Windows to PAS 024 Laminated glass may be required to all ground floor & vulnerable locations* Doors and windows adjacent to within 300mm to be laminated	All doors to be laminated & PAS 024
Silver	Windows to PAS 024 Laminated glass may be required to all ground floor & vulnerable locations* Doors and windows adjacent to within 300mm to be laminated	All doors to be laminated & PAS 024
Bronze	Windows to PAS 024 Laminated glass to all vulnerable locations Doors and windows adjacent to within 300mm to be laminated	All doors to be laminated & PAS 024

www.securedbydesign.com

### Critical locations in internal and external walls

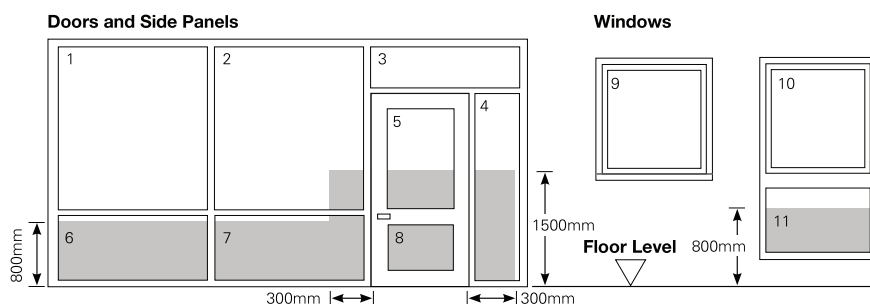

Shaded areas show critical locations to which requirement N1 applies (ie. glazing in areas numbered 2,4,5,6,7,8,11).

Source: NHBC

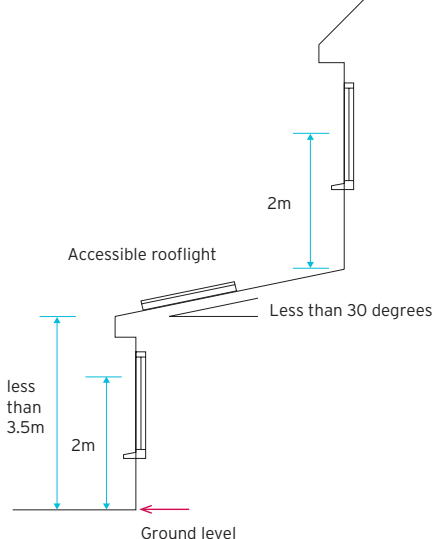

**Diagram 1**  
ADQ - Accessible windows - are windows within 2m of: ground level, flat or low pitched roofs (lowest edge within 3.5m of ground level), access balconies and basement areas.

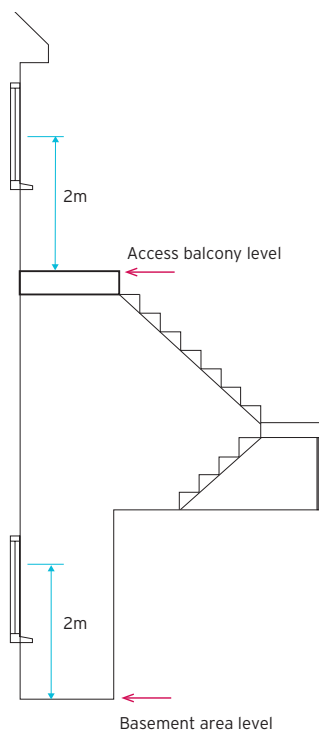

\*The Designing Out Crime Officer (DOCO) may deem this necessary in certain high crime locations to ensure that security is commensurate with the risk. Such a requirement will be justified and evidenced by the DOCO and will be communicated to the developer, or the developer's agent, in writing prior to commencement of building construction.

**Asset Finline is the Commercial Division of A&B Glass Company Ltd**

Unit 9, Mundford Road Trading Estate, Thetford, Norfolk IP24 1NB

Tel: 01842 763529 | Fax: 01842 752398 | Email: sales@assetfinline.co.uk | Visit: www.assetfinline.co.uk